

UMI0005_3

ISPI561 Evaluation Board User's Guide

Semiconductors

April 2003

User's Guide Rev. 2.0

Revision History:

Revision	Date	Description	Author
2.0	Apr 2003	Updated terminology <ul style="list-style-type: none">• “USB 1.1” to “Original USB”• “USB 2.0” to “Hi-Speed USB”• “I²C” to “I²C-bus”	Yuk-lin ONG
1.3	Mar 2003	Updated the following sections: <ul style="list-style-type: none">• Section 4.7• Section 6.2• Section 7	Teh Hock Lye
1.2	Oct 2002	Updated the following sections: <ul style="list-style-type: none">• Section 4.4, removed the last paragraph.• Section 8: Changed PSR05 to PSR05-PDI0611.	Tan Kim Kiat
1.1	July 2002	Contents update.	Socol Constantin, Adrian Albu and Teh Hock Lye
1.0	Feb 2002	First draft.	Adrian Albu and Socol Constantin

We welcome your feedback. Send it to wired.support@philips.com.

Philips Semiconductors - Asia Product Innovation Centre
Visit www.semiconductors.philips.com/buses/usb or www.flexiusb.com

PHILIPS

This is a legal agreement between you (either an individual or an entity) and Philips Semiconductors. By accepting this product, you indicate your agreement to the disclaimer specified as follows:

DISCLAIMER

PRODUCT IS DEEMED ACCEPTED BY RECIPIENT. THE PRODUCT IS PROVIDED "AS IS" WITHOUT WARRANTY OF ANY KIND. TO THE MAXIMUM EXTENT PERMITTED BY APPLICABLE LAW, PHILIPS SEMICONDUCTORS FURTHER DISCLAIMS ALL WARRANTIES, INCLUDING WITHOUT LIMITATION ANY IMPLIED WARRANTIES OF MERCHANT ABILITY, FITNESS FOR A PARTICULAR PURPOSE, AND NONINFRINGEMENT. THE ENTIRE RISK ARISING OUT OF THE USE OR PERFORMANCE OF THE PRODUCT AND DOCUMENTATION REMAINS WITH THE RECIPIENT. TO THE MAXIMUM EXTENT PERMITTED BY APPLICABLE LAW, IN NO EVENT SHALL PHILIPS SEMICONDUCTORS OR ITS SUPPLIERS BE LIABLE FOR ANY CONSEQUENTIAL, INCIDENTAL, DIRECT, INDIRECT, SPECIAL, PUNITIVE, OR OTHER DAMAGES WHATSOEVER (INCLUDING, WITHOUT LIMITATION, DAMAGES FOR LOSS OF BUSINESS PROFITS, BUSINESS INTERRUPTION, LOSS OF BUSINESS INFORMATION, OR OTHER PECUNIARY LOSS) ARISING OUT OF THIS AGREEMENT OR THE USE OF OR INABILITY TO USE THE PRODUCT, EVEN IF PHILIPS SEMICONDUCTORS HAS BEEN ADVISED OF THE POSSIBILITY OF SUCH DAMAGES.

CONTENTS

1.	INTRODUCTION	4
2.	ISPI561 PIN CONFIGURATION	5
3.	SYSTEM REQUIREMENTS	5
4.	ISPI561 EVALUATION BOARD	6
4.1.	PORT POWERED LEDs	6
4.2.	GOODLINK LEDs.....	6
4.3.	V _{AUX} POWER SUPPLY.....	6
4.4.	LEGACY SUPPORT	7
4.5.	INPUT CLOCK.....	8
4.6.	EXTERNAL 5 V POWER SOURCE AND S3 WAKE-UP CAPABILITY.....	8
4.7.	LOADING THE SUBSYSTEM ID AND VENDOR ID FROM THE EXTERNAL EEPROM.....	8
5.	HI-SPEED USB (EHCI) DRIVERS	9
6.	LOADING OF THE ISPI561 DRIVERS	10
6.1.	LOADING OF OHCI DRIVERS.....	10
6.2.	LOADING OF EHCI DRIVERS	13
7.	SCHEMATICS	15
8.	BILL OF MATERIALS	19
9.	REFERENCES	20

FIGURES

Figure 1-1:	ISPI561 Evaluation Board.....	4
Figure 2-1:	Pin Configuration.....	5
Figure 4-1:	Evaluation Board Schematic.....	6
Figure 4-2:	Block Diagram of Legacy Signal Connection and Testing	7
Figure 4-3:	I ² C-bus EEPROM Programming Example.....	9

I²C-bus is a registered trademark and GoodLink is a trademark of Koninklijke Philips Electronics N.V. Microsoft and Windows are either registered trademarks or trademarks of Microsoft Corp. in the United States and/or other countries. Intel is a registered trademark of Intel, Inc. The names of actual companies and products mentioned herein may be the trademarks of their respective owners. All other names, products, and trademarks are the property of their respective owners.

I. Introduction

The ISPI561 evaluation board is a standard implementation of the ISPI561 in a complete configuration that allows you to exercise all signals and main features. Figure I-1 shows the ISPI561 evaluation board.

Some of the features that are implemented in the ISPI561 evaluation board are as follows:

- Selection between PCI V_{AUX} and PCI V_{CC} power supply, with voltage presence indicator. This feature in combination with the auxiliary +5 V input on J1 allows testing the system wake-up from power management states, such as S3cold, in which PCI V_{CC} is not present. This is intended mainly for testing the ISPI561 in motherboard or notebook designs.
- Selection between 12 MHz clock (from a crystal) or 48 MHz clock (from a 48 MHz oscillator) input. By default, 12 MHz crystal is implemented.
- Simple and reliable overcurrent protection scheme that allows testing of the \overline{OCn} and \overline{PWEn} signals. Alternative solutions (resettable circuit protection devices) can be adopted.
- Port power and GoodLink™ LEDs. These may be omitted in a standard commercial implementation but are considered useful on the evaluation board for easier understanding of functionality and debugging.
- Connector for testing legacy signals in the case of an on-board solution design. Testing the legacy feature requires a motherboard with BIOS support for USB or legacy implementation on OHCI.
- Input for an external power supply (J1). This allows complete testing of power management on a standard mainboard, including the power management modes in which the PCI +5 V is cut off.

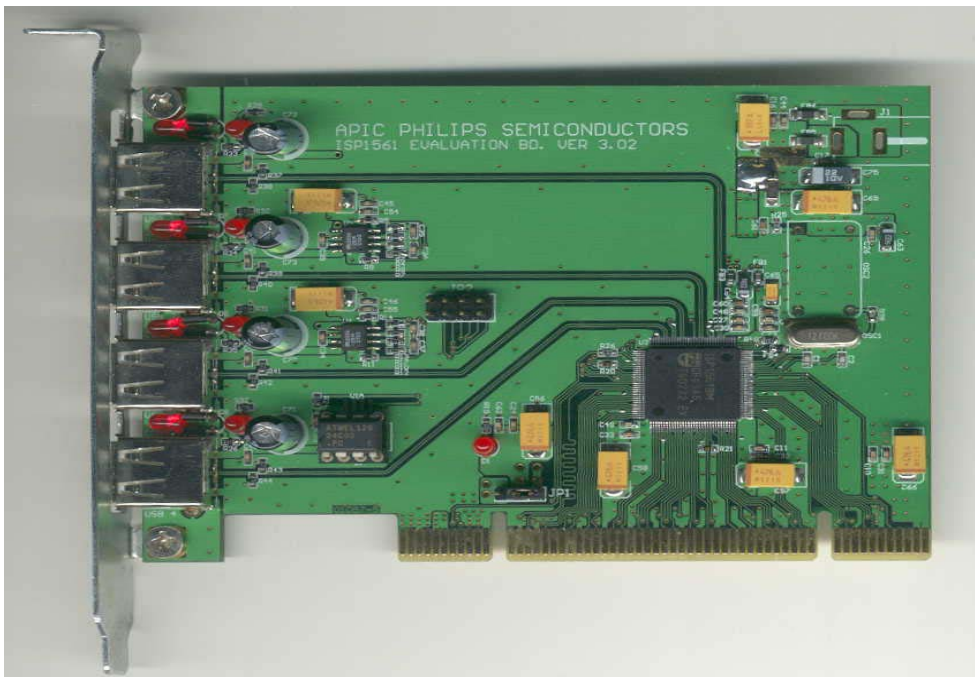

Figure I-1: ISPI561 Evaluation Board

2. ISPI561 Pin Configuration

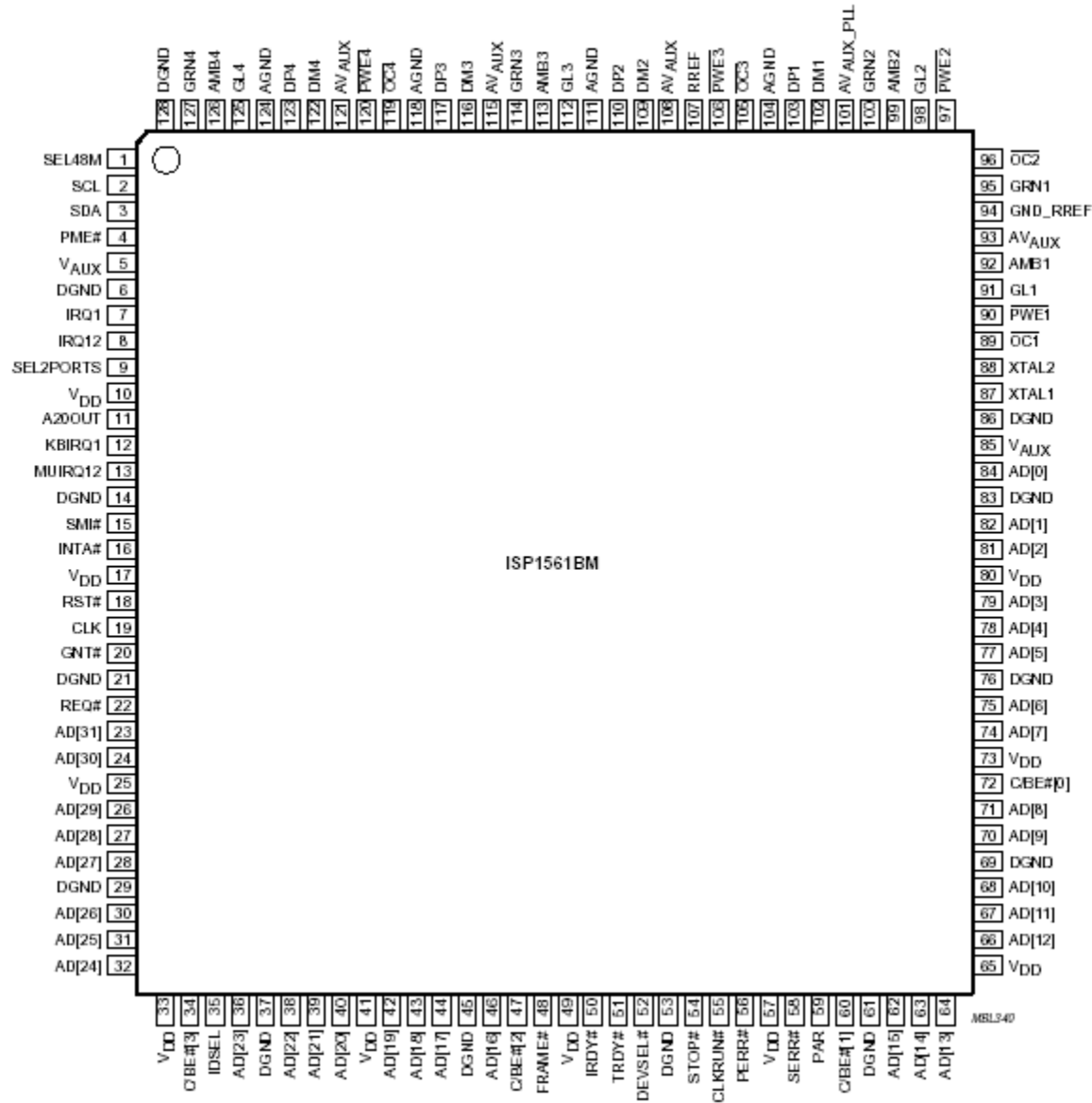

Figure 2-1: Pin Configuration

3. System Requirements

- Intel® PII400 MHz processor and above, or equivalent in speed from AMD®, Cyrix® and VIA®, is recommended.

Generally, the processor usage indicator will vary according to the type and number of applications launched for the exercising USB devices attached. For example, running data transfer tests on two high-speed (HS) hard disk drives (HDDs) on a P4 at 1.7 GHz, 128 Mbytes DDRAM, Microsoft® Windows® 2000 will determine a processor usage figure of 30% to 40%. Adding two Original USB cameras and an application playing MP3 song through Original USB speakers may increase the average processor usage figure up to 70% to 80%. Also, a Hi-Speed USB camera and an Original USB camera running simultaneously will increase the processor usage up to 100% (depending on resolution settings).

- Motherboard with PCI slots that are compatible with *PCI Local Bus Specification, Rev. 2.2* (Supporting at least S1 and S3 power management modes for power management features testing).
- Memory: Minimum amount as indicated by the operating system and applications requirements, similar to processor speed requirement mentioned earlier. Only a small amount of memory is occupied by the installation of the device drivers itself or OHCI/EHCI functionality.
- HDD space: Mainly determined by the operating system and applications requirements because specific drivers need very little space.
- Graphics cards, other adapter cards: No special requirements.
- Operating systems supported: Windows 98 Second Edition (SE), Windows 2000, Windows XP and Windows Millennium Edition (Me).

4. ISPI56I Evaluation Board

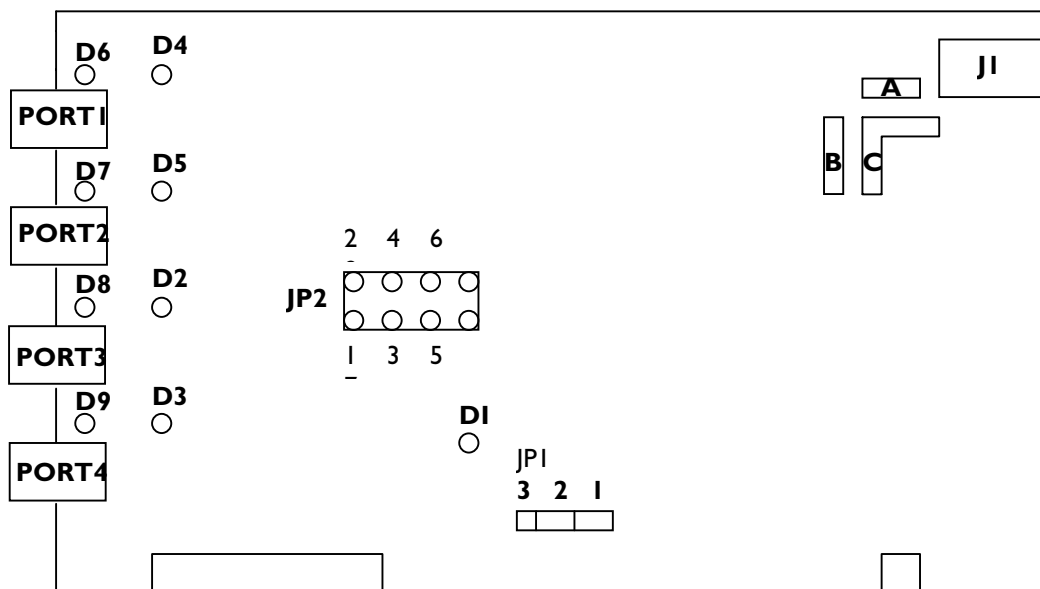

Figure 4-1: Evaluation Board Schematic

4.1. Port Powered LEDs

LEDs D2, D3, D4 and D5 indicate the power status of USB ports. If a port is powered, the respective LED is turned on. It is turned off during system boot-up until OHCI or EHCI drivers are loaded, or it is switched off whenever an overcurrent condition occurs.

4.2. GoodLink LEDs

LEDs D6, D7, D8 and D9 are GoodLink indicators. These LEDs blink when a device is connected to the respective port indicating port activity.

4.3. V_{AUX} Power Supply

If the motherboard used is PCI 2.2 compliant, jumper JPI position 2-3 may be shorted, allowing S3cold suspend and resume testing (PCI $V_{AUX} = 3.3$ V is used and an external +5 V is necessary). If the motherboard used is PCI 2.1 or older version compliant, jumper JPI position 1-2 must be shorted (PCI $V_{CC} = 3.3$ V is used because V_{AUX} is not present). Note that in both these situations LED D1 must be turned on indicating that the ISPI56I is powered.

Important: If the LED DI is not lit, it indicates that the ISPI561 does not have the V_{AUX} supply (V_{AUX} is not supplied in the PCI connector). Therefore, your computer will stop responding or 'hang' when the operating system is loading OHCI or EHCI drivers. Switch JPI to position 1-2 to connect to the PCI $V_{CC} = 3.3\text{ V}$ (present under normal conditions, except some system power management modes, for example, S3cold and S4).

4.4. Legacy Support

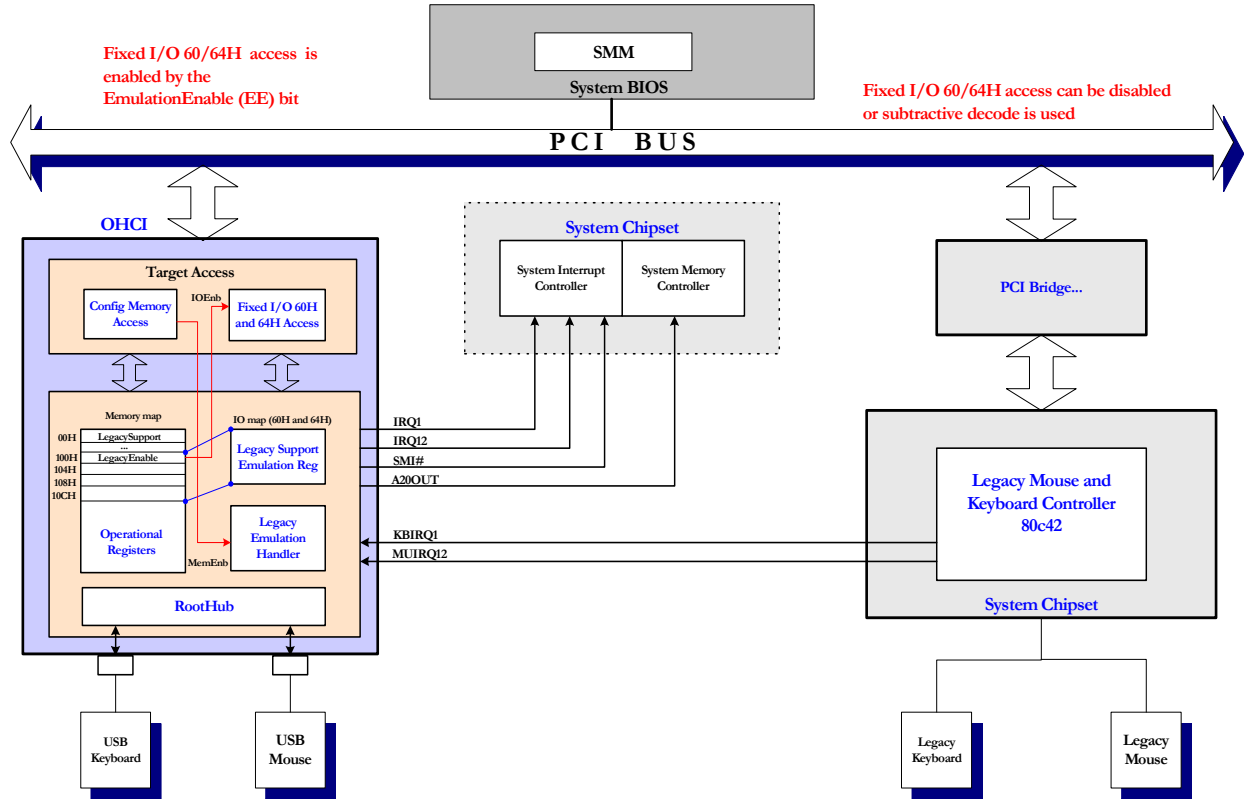

Figure 4-2: Block Diagram of Legacy Signal Connection and Testing

Figure 4-2 shows the necessary connections for testing the legacy support functionality. The necessary signals must be accessible on the motherboard used for legacy testing.

Testing	R22	R23	R2	R3
Legacy support	— ^[1]	— ^[1]	10 kΩ	10 kΩ
Default setting (No legacy support)	0 Ω	0 Ω	10 kΩ	10 kΩ

[1] When testing the legacy support, resistors R22 and R23 (or the pull-down resistors located at the bottom of the evaluation board) must be removed.

The JP2 connector is used for testing the keyboard and mouse legacy support.

Pin Number	Signal
1	GND
2	GND
3	A20OUT
4	SMI#
5	KBIRQ1
6	IRQ12
7	MUIRQ12
8	IRQ1

4.5. Input Clock

You can use either the 12 MHz crystal or the 48 MHz oscillator for the input clock. If the 12 MHz crystal is used, both the resistors (R1 and R27) are soldered. If the 48 MHz oscillator is used, resistor R27 (0 Ω) must be removed and pin 1 is pulled HIGH by R1. By default, the 12 MHz solution is implemented on the evaluation board.

4.6. External 5 V Power Source and S3 Wake-Up Capability

The jack J1 is used for connection of an external +5 V standby power supply to test the system wake-up from S3cold and maintain the connected USB devices powered so that re-enumeration is avoided.

When the system is in the S3cold Power Management State, the +5 V main power at PCI connectors disappears. Therefore, all downstream ports will not be powered because V_{BUS} is derived from the PCI +5 V power supply. In this situation, downstream bus-powered devices, such as mouse and keyboard, are not functional and cannot wake up the system.

If you want to use the external +5 V supply, pads A and C on the evaluation board must be soldered together as represented in the evaluation board drawing. Similarly, if you only intend to use PCI +5 V as the V_{BUS} power source (no testing of the system wake-up from S3cold and no external +5 V connected), then pads B and C must be soldered together. Pads A, B and C are copper areas on the upper-right corner of the evaluation board (see Figure 4-1). This solution, using three copper pads, was adopted to avoid using a jumper because only the default configuration (pads B and C connected together) will be used most of the time.

4.7. Loading the Subsystem ID and Vendor ID from the External EEPROM

Expansion board vendors can use the Subsystem Vendor ID and the Subsystem ID for identification of the board and loading of the correct drivers by the operating system. The PCI SIG assigns the Subsystem Vendor ID and the vendor determines the Subsystem ID.

The Subsystem Vendor ID and the Subsystem ID can be optionally loaded at power-on from the external serial I²C-bus® EEPROM present on the ISPI561 evaluation board. A 3.3 V serial EEPROM of any size can be used because only a few locations will be used for data loading.

The serial I²C-bus EEPROM present on the ISPI561 evaluation board cannot be programmed onboard. It should be preprogrammed by using a standard serial EEPROM programmer. A socket is provided on the ISPI561 evaluation board for repetitive reprogramming of the EEPROM.

An example on the I²C-bus EEPROM programming is given in Figure 4-3. In the example, it is assumed that the Subsystem Vendor ID is 1132H, the Subsystem Device ID for OHCI is 1664H, and the Subsystem Device ID for EHCI is 1665H.

Address	I ² C-Bus EEPROM Content	
0	32H	Subsystem Vendor ID—LOW
1	11H	Subsystem Vendor ID—HIGH
2	64H	Subsystem Device ID (OHCI)—LOW
3	16H	Subsystem Device ID (OHCI)—HIGH
4	65H	Subsystem Device ID (EHCI)—LOW
5	16H	Subsystem Device ID (EHCI)—HIGH
6	FFH	reserved
7	15H ^[1]	reserved

[1] Loads Subsystem Vendor ID and Device ID. For more details, refer to the *ISPI561 Hi-Speed USB PCI host controller* datasheet.

Figure 4-3: I²C-bus EEPROM Programming Example

Note: Do not load any other values in reserved fields, otherwise, functionality of the ISPI561 is not guaranteed.

5. Hi-Speed USB (EHCI) Drivers

For Windows 2000 and Windows XP, the standard Microsoft EHCI drivers can be used. The best way to obtain the latest EHCI drivers is to download from the Microsoft web site. Installation or update of EHCI device drivers for the supported operating systems follows the standard installation procedure for device drivers, and so should not present any difficulty.

However, the `usb2.inf` file must be modified to match the Philips Vendor ID (VID), Device ID (DID) and IC revision code.

If there are difficulties in loading the Hi-Speed USB (EHCI) drivers, particularly for Windows 2000 and Windows XP, the first step is to check the correctness of the VID, DID and REV_ID specified in the INF file. These values must match with the values implemented in the respective revision of the ISPI561 found on the evaluation board.

An example of the necessary modifications that must be made to a `usb2.inf` file is as follows. The file example contains information regarding the ISPI561 VID, DID and REV_ID. These modifications are similar for Windows 2000 and Windows XP.

1. Add the following line of code under the **[Manufacturer]** section:

```
%Philips%=Philips
```

2. Under the **USB 2.0 Hub Support** section, add the following lines of code:

```
; ===== Philips =====
[Philips]
; for Windows 2000
%PCI\VEN_1131&DEV_1562&REV_30.DeviceDesc%=EHCI, PCI\VEN_1131&DEV_1562&REV_30
%USB\ROOT_HUB20.DeviceDesc%=ROOTHUB2, USB\ROOT_HUB20
; HUBs
%USB\HubClass.DeviceDesc%=Usb2Hub.Dev, USB\HubClass
```

3. Add the following lines of code under the **[Strings]** section:

```
Philips="Philips"
PCI\VEN_1131&DEV_1562&REV_30.DeviceDesc="PHILIPS PCI to USB Enhanced Host Controller ES5"
```

For Windows 98 and Windows Me, Philips provides EHCI device drivers; no modification in its INF file is required.

Windows 98, Windows Me, Windows 2000 and Windows XP supply the device drivers for OHCI by default.

6. Loading of the ISPI561 Drivers

This section provides an example on loading device drivers after an ISPI561 add-on card is plugged into a computer running Windows 98. Loading of OHCI drivers (supplied by the operating system) and Hi-Speed USB (EHCI) drivers provided by Philips is shown in a step-by-step process.

Note: In the case of Windows 2000 and Windows XP, OHCI drivers are automatically installed by the operating system without any user intervention.

6.1. Loading of OHCI Drivers

The following wizard appears when an ISPI561 add-in card is plugged on a computer running Windows 98, enabling you to install OHCI drivers.



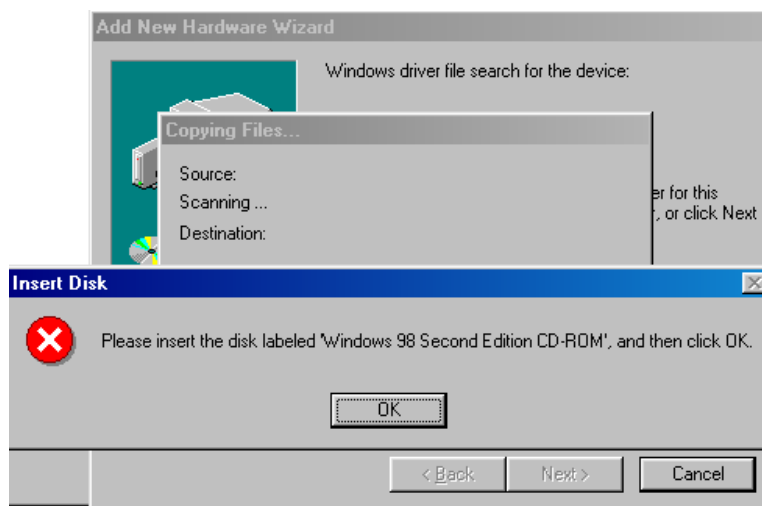

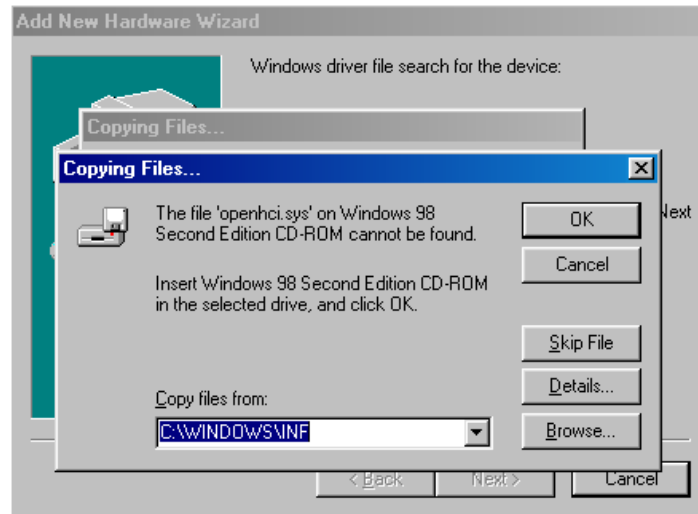

Click the **Browse** button and locate the path where the Windows 98 kit is installed.

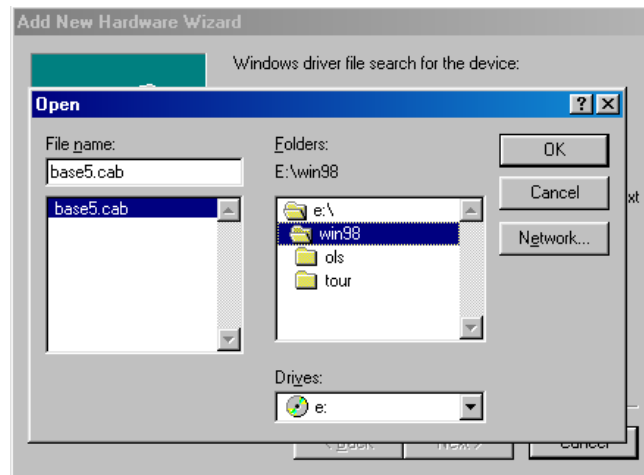

Note: The preceding steps will be repeated twice for loading of the drivers for the two OHCI (OHCI1 and OHCI2).

6.2. Loading of EHCI Drivers

After the drivers have been loaded for OHCI1 and OHCI2, the following wizard appears, when an ISPI561 add-on card is plugged on to a computer running Windows 98, enabling you to install the Hi-Speed USB EHCI drivers.







For your reference, the contents of the Windows 98/Windows Me EHCI driver are as follows:

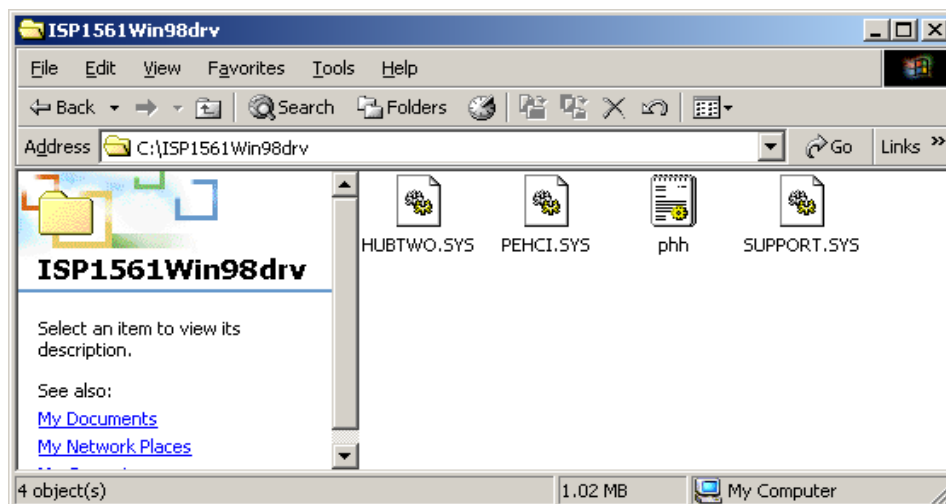

7. Schematics

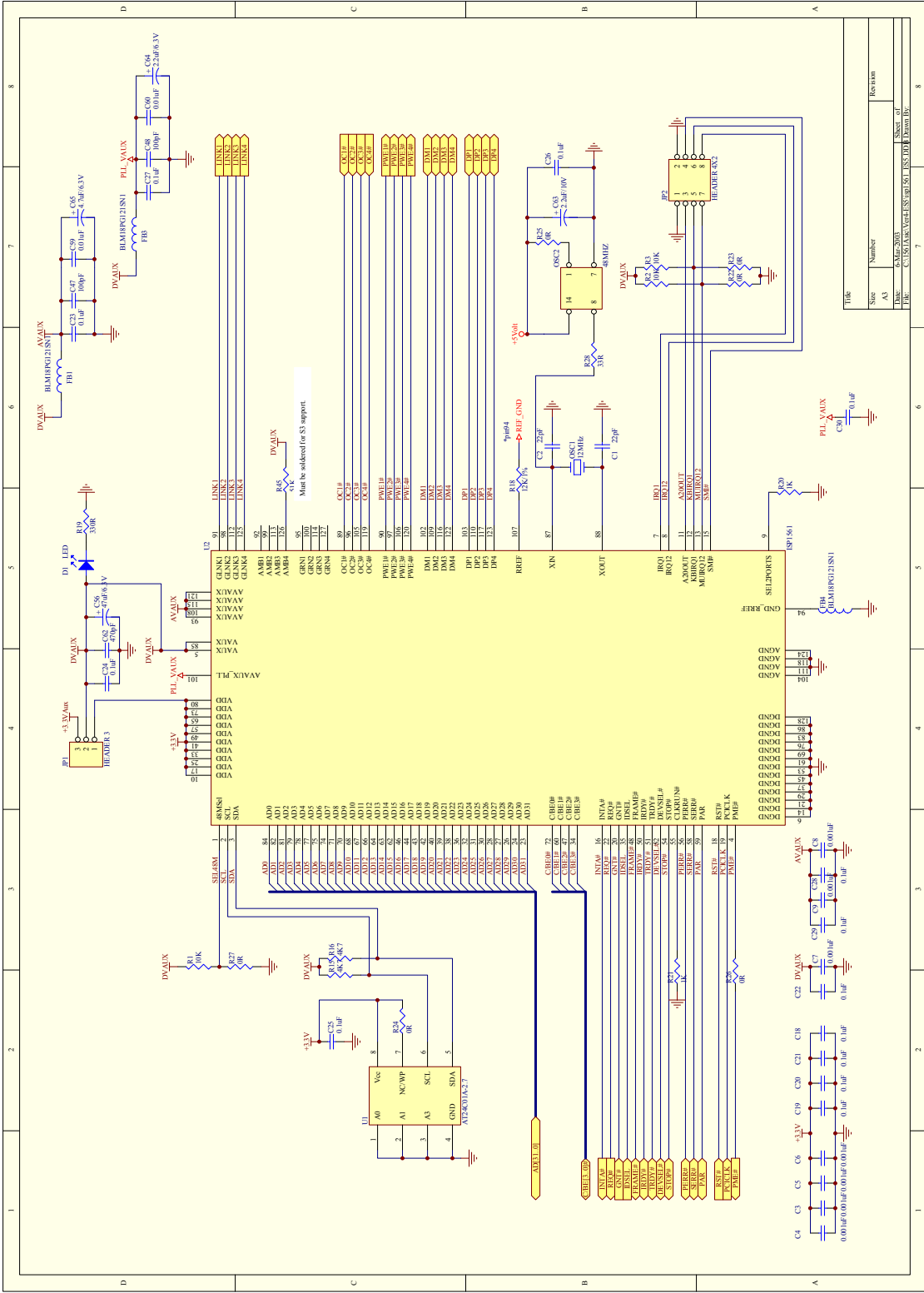

File	Size	Number	Revision
AI	10.5K	1001	1
HW	10.5K	1001	1
HW	10.5K	1001	1

FILE: C:\TRIAL\AVR\AT91SAM7S128\HW\HW.DWG
 DATE: 2004/08/10

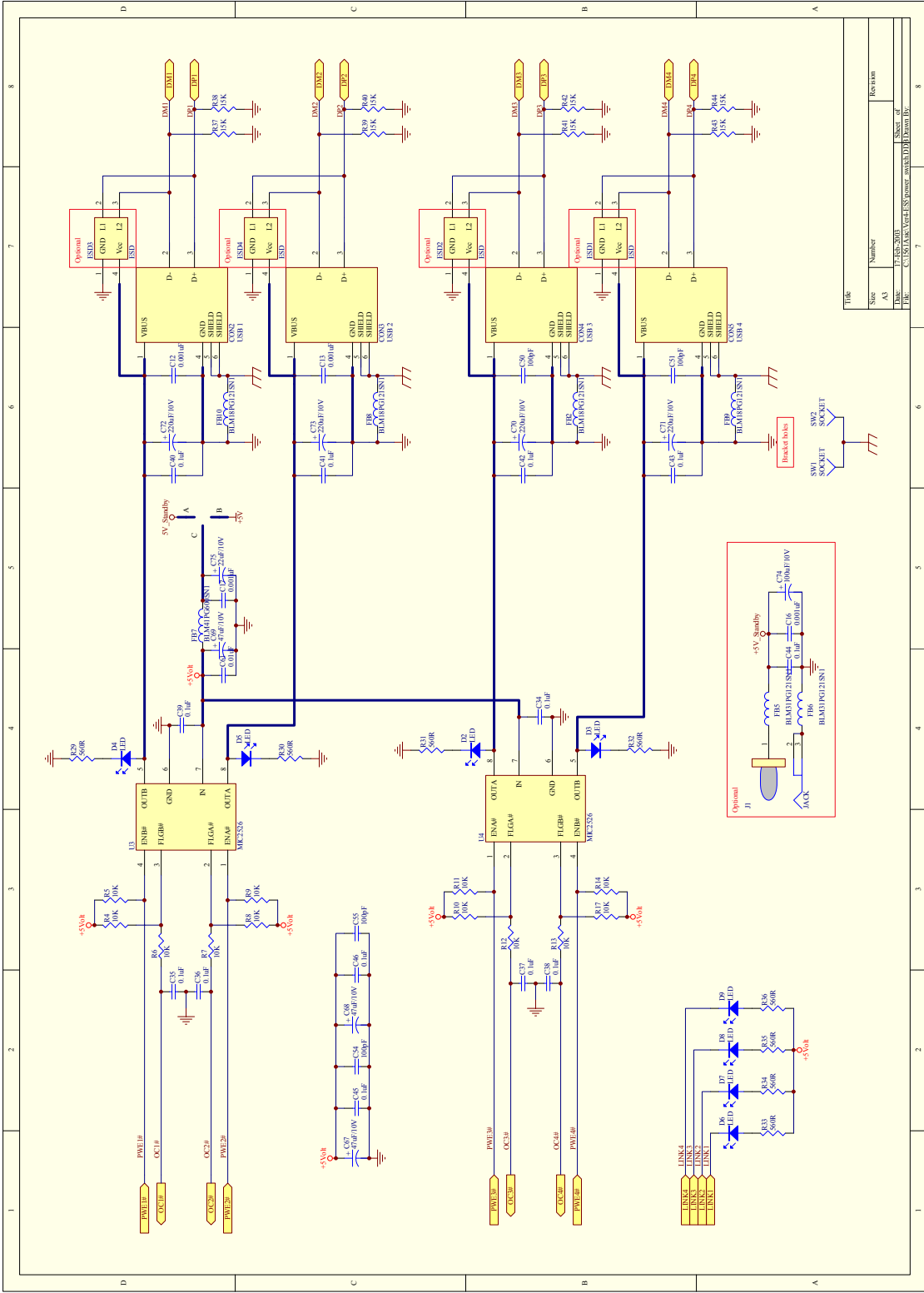

Size	Number	Revision
A1	1	1
FILE NAME	POWER_SUPPLY	Sheet 7
FILE NO.	CU1801AN_V04E115_Power_supply.DWG	Drawn By

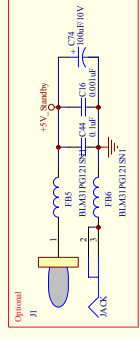

8. Bill of Materials

The following table provides the bill of materials for the ISPI561 evaluation board.

Quantity	Part Type	Designator	Footprint	Description
2	—	JP3 JP4	RADO.2	—
13	0.001 μ F	C3 C4 C5 C6 C7 C8 C9 C10 C11 C12 C13 C16 C17	0603	—
3	0.01 μ F	C59 C60 C61	0603	—
29	0.1 μ F	C18 C19 C20 C21 C22 C23 C24 C25 C26 C27 C28 C29 C30 C31 C32 C33 C34 C35 C36 C37 C38 C39 C40 C41 C42 C43 C44 C45 C46	0603	—
6	0 Ω	R22 R23 R24 R25 R26 R27	0603	—
7	100 pF	C47 C48 C49 C50 C51 C54 C55	0603	—
1	100 μ F/10 V	C74	REC1/2	—
14	10 k Ω	R1 R2 R3 R4 R5 R6 R7 R8 R9 R10 R11 R12 R13 R14	0603	—
1	12 k Ω \pm 1%	R18	0603	—
1	12 MHz	OSC1	XTAL1	30 ppm
8	15 k Ω	R37 R38 R39 R40 R41 R42 R43 R44	0603	—
2	1 k Ω	R20 R21	0603	—
1	2.2 μ F /10 V	C63	—	—
1	2.2 μ F /6.3 V	C64	—	—
4	220 μ F/10 V	C70 C71 C72 C73	REC1/2	—
2	22 pF	C1 C2	0603	—
1	22 μ F/10 V	C75	REC1/2	—
1	330 Ω	R19	0603	—
1	33 Ω	R28	—	—
1	4.7 μ F/6.3 V	C65	—	—
1	470 pF	C62	0603	—
4	47 μ F/10 V	C66 C67 C68 C69	CASE-D	—
3	47 μ F /6.3 V	C56 C57 C58	CASE-D	—
1	48 MHz	OSC2	XTAL3	30 to 50 ppm, optional
3	4 k Ω	R15 R16 R17	0603	—
8	560 Ω	R29 R30 R31 R32 R33 R34 R35 R36	0603	optional
1	51 k Ω	R45	0603	optional
1	AT24C01A-2.7	U1	—	Atmel I ² C-bus EEPROM; optional
7	BLM18PG121SN1	FB1 FB2 FB3 FB4 FB8 FB9 FB10	—	Murata
2	BLM31PG121SN1	FB5 FB6	1206	Murata; optional
1	BLM41PG600SN1	FB7	1206Cust	Murata; optional
4	ESD	ESD1 ESD2 ESD3 ESD4	—	PSR05-PDI0611 - Protek devices; optional
1	HEADER 3	JP1	SIP3	Optional
1	HEADER 4X2	JP2	—	Optional
1	ISPI561	U2	—	Philips
1	JACK	J1	—	PCB mount socket pin diameter 2.5; optional
9	LED	D1 D2 D3 D4 D5 D6 D7 D8 D9	LED3	Optional

Quantity	Part Type	Designator	Footprint	Description
2	MIC2526	U3 U4	SO-8	Micrel
1	USB 1	CON2	USB-TYPEA	—
1	USB 2	CON3	USB-TYPEA	—
1	USB 3	CON4	USB-TYPEA	—
1	USB 4	CON5	USB-TYPEA	—

9. References

- *ISPI561 Hi-Speed USB PCI host controller datasheet*
- *Designing a USB 2.0 Host PCI Adapter Using ISPI561 application note*
- *Universal Serial Bus System Architecture, First and Second Editions from MindShare*
- *Universal Serial Bus Specification Rev. 1.1*
- *Universal Serial Bus Specification Rev. 2.0*
- *PCI Local Bus Specification, Rev. 2.2*
- *PCI Bus Power Management Interface Specification, Rev. 1.1*
- *PCI System Architecture, Fourth Edition from MindShare.*

Philips Semiconductors

Philips Semiconductors is a worldwide company with over 100 sales offices in more than 50 countries. For a complete up-to-date list of our sales offices please e-mail sales.addresses@www.semiconductors.philips.com. A complete list will be sent to you automatically. You can also visit our website <http://www.semiconductors.philips.com/sales/>

www.semiconductors.philips.com

© **Koninklijke Philips Electronics N.V. 2003**

All rights reserved. Reproduction in whole or in part is prohibited without the prior written consent of the copyright owner. The information presented in this document does not form part of any quotation or contract, is believed to be accurate and reliable and may be changed without notice. No liability will be accepted by the publisher for any consequence of its use. Publication thereof does not convey or imply any license under patent – or other industrial or intellectual property rights.

